

SHIMANO NEXUS AUTO-D  
**AI-3S30**

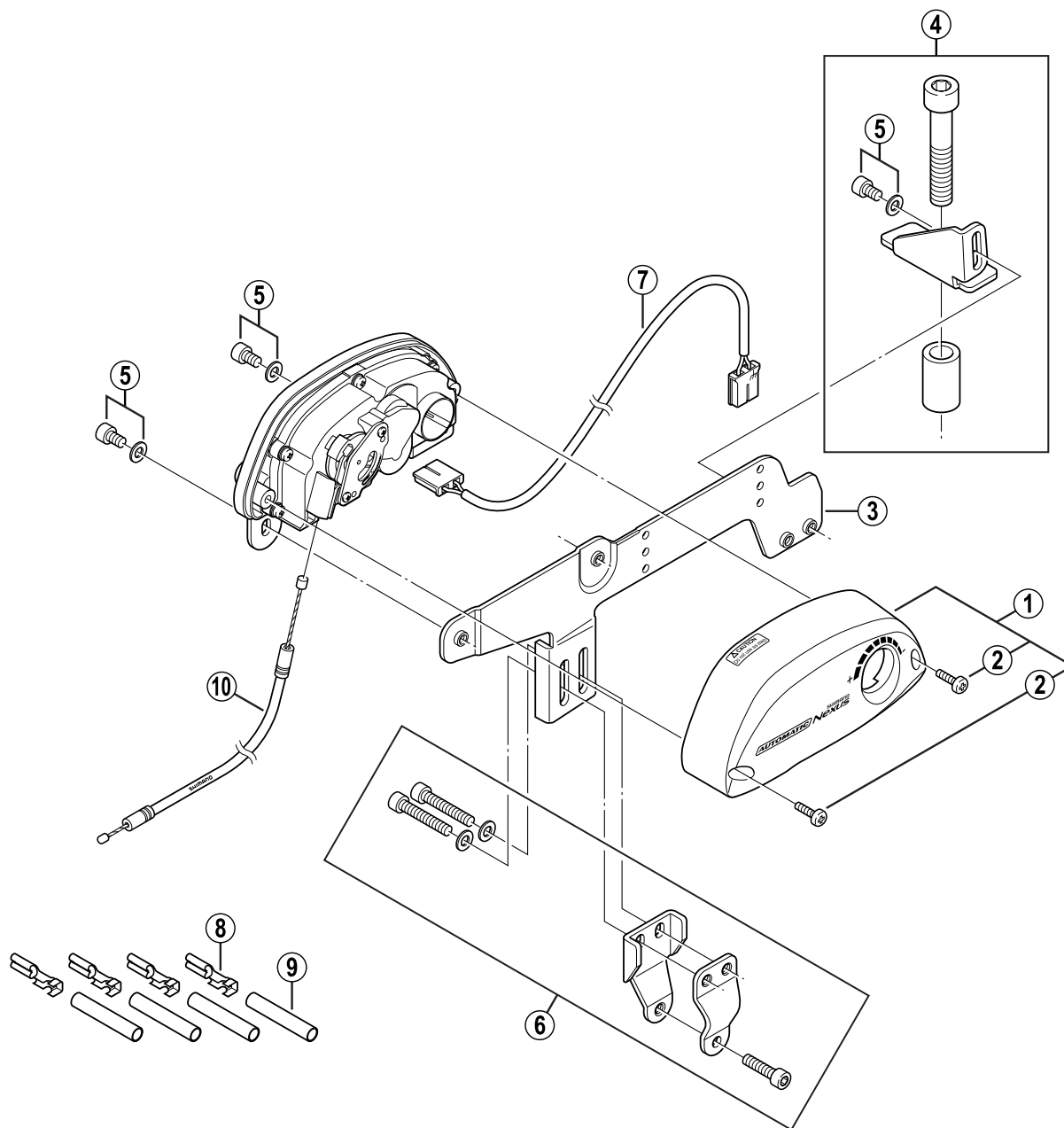

Q'TY	ITEM NO.	SHIMANO CODE NO.	DESCRIPTION
	1	Y-7B7 98010	Main Unit Cover & Fixing Screws
	2	Y-7B7 13000	Cover Fixing Screw
	3	Y-7B7 14000	Installation Base
	4	Y-7B7 98030	Installation Base B Unit
	5	Y-7B7 98040	Main Unit Fixing Bolt (M5 x 8) & Washer
	6	Y-7B7 98050	Installation Band Unit
	7	Y-7B7 98060	Cable (1850 mm) w/Connection Terminal
	8	Y-7B7 23000	Connection Terminal
	9	Y-7B7 30000	Terminal Cover
	10	Y-7B7 24000	LS-AI3S30 Cable Set (225 mm)

## General Safety Information

**⚠ WARNING** – To avoid serious injuries:

- Obtain and read the service instructions carefully prior to installing the parts. Loose, worn, or damaged parts may cause serious injury to the rider. We strongly recommend only using genuine Shimano replacement parts.
- Read these Technical Service Instructions carefully, and keep them in a safe place for later reference.

**⚠ CAUTION** – To avoid serious injuries:

The Automatic Inter-3 is an automatic gear shifting system in which the shifting points are determined by the speed of the bicycle (the rotating speed of the wheels). Because of this, gear shifting can occur independently of the rider's intentions, and so shocks may be felt during shifting. Make sure that you understand and become accustomed to these shifting characteristics before using the system extensively.

### NOTE:

- The Automatic Inter-3 returns to 1st gear when the bicycle stops.
- When riding the bicycle, a beep will be heard before a gear shift occurs to notify the rider that a gear shift is about to take place.
- The riding lamps may periodically become darker than usual, but this is not a sign of a problem. It happens when the power required to run the system is being recharged, such as when the gear shifting motor has operated.
- Use a dry cloth or a cloth that is lightly moistened with neutral detergent to clean the unit. Solvents such as thinner will damage the unit's surface.
- Parts are not guaranteed against natural wear or deterioration resulting from normal use.

CE SI-7B70B

# AI-3S30

Automatic Inter-3

## Technical Service Instructions

### Operation of the 8-mode switch

The gear shifting timing can be adjusted to one of eight settings.

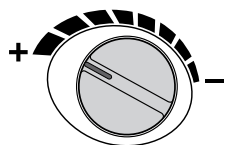

- **If you prefer slower, firmer pedaling**  
+ : Gear shifting timing is advanced
- **If you prefer faster pedaling**  
- : Gear shifting timing is delayed

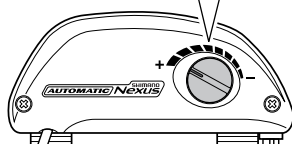

## N position adjustment

1. Use a Phillips screwdriver to loosen the two cover fixing screws, and then remove the main unit cover.

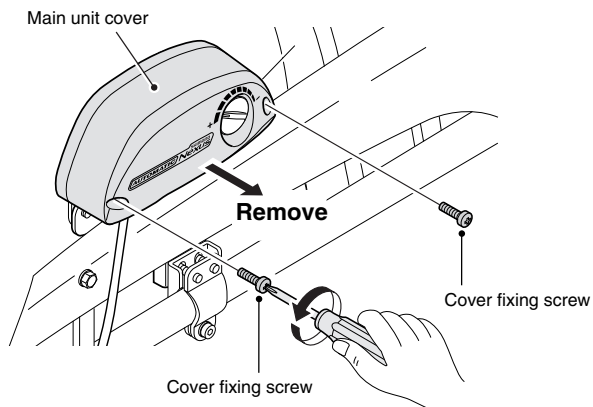

2. Insert a 5 mm Allen key into the hexagonal recess in the winder unit as shown in the illustration, and use it to turn the winder unit in the direction of the arrow until it is against the stopper.

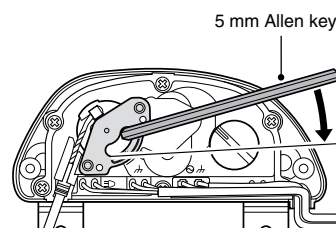

3. Next, turn the winder unit back in the direction of the arrow until it stops (N position).

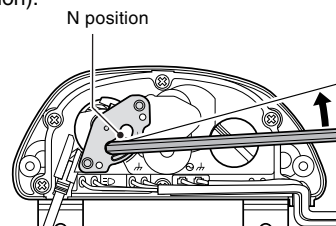

4. In this position, turn the cable adjustment bolt of the bell crank counterclockwise so that the end of the hub axle and the red line on the push rod are aligned.

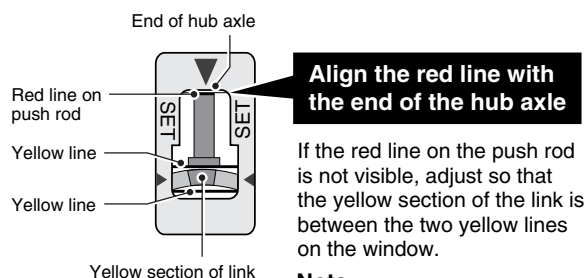
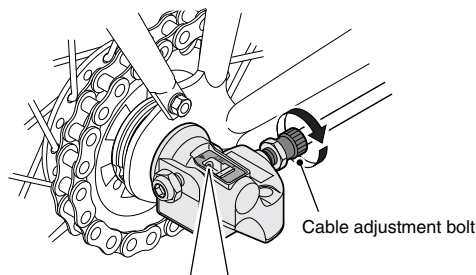

If the red line on the push rod is not visible, adjust so that the yellow section of the link is between the two yellow lines on the window.

### Note:

Look at the two yellow lines from directly above during adjustment.

5. Turn the front wheel to charge the power. When the power is fully charged, the gear will shift automatically from the N position to the L position.

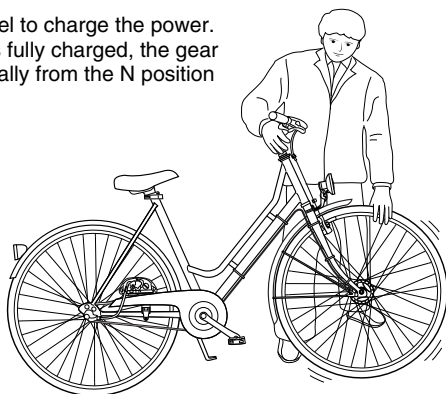

6. Rotate the front wheel rapidly and check that the gears change from 1st to 2nd to 3rd. If the gear does not change from 2nd to 3rd, stop rotating the front wheel and turn the cable adjustment bolt of the bell crank half a turn clockwise. After this, check the shifting of the gears once more.

7. After adjusting the bell crank, secure the cable adjustment bolt by tightening the cable adjustment nut.

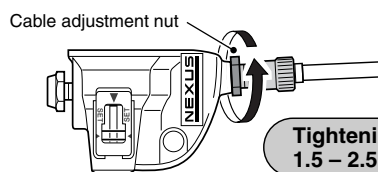

**Tightening torque:**  
1.5 – 2.5 Nm {15 – 25 kgfcm}

8. Install the main unit cover while making sure that the cable is routed correctly, and then securely tighten the two cover fixing screws.

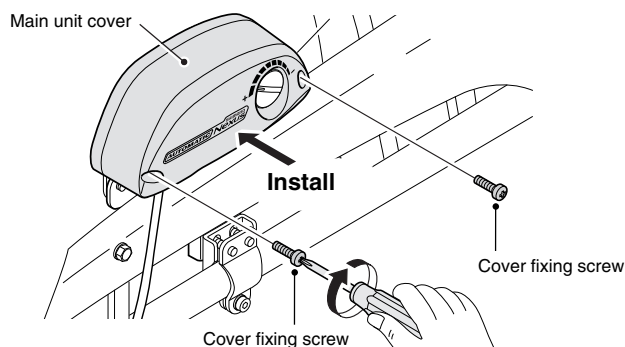

**Tightening torque:**  
1 – 1.5 Nm {10 – 15 kgfcm}

## Checking lamp illumination

While covering the illumination sensor receiving window at the rear of the main unit with your hand, turn the front wheel and check that the lamp lights.

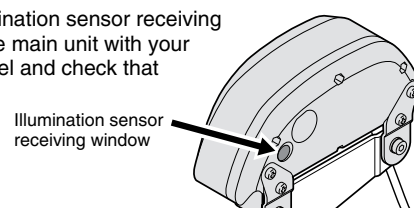

## Troubleshooting

For any questions regarding installation or adjustments, please contact the place of purchase.

Symptom	Check	Remedy
<b>No gear shifting occurs.</b>	Are the cables connected correctly?	Connect the cables correctly between the main unit and the hub dynamo, and between the main unit and the lamp stay.
	Is the gear shifting cable connected correctly?	Connect the cable correctly at the main unit and bell crank.
	Is the gear shifting cable broken?	Replace the cable with a new one.
	Is the frame grounded electrically?	Check if the main unit installation is too loose. Install the toothed washer in the correct position.
	Are the proper lamp bulbs being used? (If the electrical load is too great, the power required for shifting may not be supplied.)	Use the proper lamp bulbs (Front lamp: 6 V/2.4 W; Taillamp: 6 V/0.6 W).
<b>Gears do not shift above 2nd.</b>	Is the 8-mode switch at the "-" position? (The speed may not have reached the speed required for shifting to 3rd.)	Set the 8-mode switch to the "+" position.
<b>A long beep sounds and no gear shifting occurs.</b>	Does the bell crank move smoothly?	Replace with a new part, or eliminate the cause of the problem.
	Does the push rod move smoothly?	Replace with a new part, or eliminate the cause of the problem.
	Is the proper push rod being used?	Use the proper push rod.
	Does the gear shifting cable work smoothly?	Replace with a new part, or eliminate the cause of the problem.
	Is the shifting cable winder on the main unit blocked with mud or small stones?	Remove the cause of the problem.
	Has the N position been adjusted correctly?	Refer to "N position adjustment".
<b>The lamp does not illuminate.</b>	Are the cables connected correctly?	Connect the cables correctly between the main unit and the hub dynamo, between the main unit and the lamp stay, and between the main unit and the lamp.
	Is the frame grounded electrically?	Check if the main unit installation is too loose. Install the toothed washer in the correct position.
	Are the surroundings dark? (The sensor detects light and has a circuit that automatically turns the lamp on and off.)	Refer to "Checking lamp illumination".
	Are the proper lamp bulbs being used?	Use the proper lamp bulbs (Front lamp: 6 V/2.4 W; Taillamp: 6 V/0.6 W).
	Are the lamp bulbs blown?	Replace the lamp bulb with a new one.
<b>The lamp stays illuminated while riding.</b>	Is the illumination sensor receiving window covered with mud?	Clean away the mud.

These service instructions explain how to use and maintain the Shimano bicycle parts which have been used on your new bicycle. For any questions regarding your bicycle or other matters which are not related to Shimano parts, please contact the place of purchase or the bicycle manufacturer.

# SHIMANO®

SHIMANO AMERICAN CORPORATION  
One Holland, Irvine, California 92618, U.S.A. Phone: +1-949-951-5003

SHIMANO EUROPE HOLDING B.V.  
Industrieweg 24, 8071 CT Nunspeet, The Netherlands Phone: +31-341-272222

SHIMANO INC.  
3-77 Oimatsu-cho, Sakai, Osaka 590-8577, Japan